



## DW30

### Wheel Dumper

Safe operation, comfortable transportation.

The DW30 provides the ideal harmonization of high safety standards and extensive equipment for many application options. Whether with a cabin or roll bar, with concrete skip or swivel tip skip: it is individually adaptable ex works, making it a real all-rounder for any construction site. It simultaneously provides a 3-ton payload at low dimensions, which means it can be efficiently applied, even in areas that are more difficult to access. For the precise placement of materials in concreting works, the optional concrete skip is equipped with a pouring pan. The DW30 provides a very high level of safety equipment both as standard and across all available versions.

### Highlights

- Skip monitoring
- Inclination monitoring
- Seat belt monitoring with start release
- Hydrostatic 4-wheel drive
- Concrete skip

### Technical Data

#### Hydraulic

Operating pressure hydraulics	150.0 bar
Hydraulic pump	ZRP
Flow rate	23.0 l/min

#### Mechanical - Output Details

Travel speed	20.0 km/h
--------------	-----------

#### Mechanical Details

Length	3,906.0 mm
Width	1,730.0 mm
Height	2,799.0 mm
Payload	3,000.0 kg
Skip	Swivel skip
Skip capacity levelled	1,280.0 l
Skip capacity heaped	1,750.0 l
Skip capacity waterlevel	990.0 l
Pendulum angle	12.0 °
Operating weight (min.-max.)	2,048.0 - 2,506.0 kg

#### Engine

Cooling	Water-cooling
Engine type	Diesel engine

Cylinder	3.0
Cylinder capacity	1,116.0 cm <sup>3</sup>
Inclined position max.	25.0 °
Fuel	Diesel EN 590
Effective power	18.9 KW
Nominal Engine speed	3,000.0 1/min
Exhaust-gas limit	EU Stage V
Starter battery Voltage	12.0 V
Engine Manufacturer	Yanmar
Engine Designation	3TNV76-UDWN

#### Environment Data

Sound power LWA, measured	98.1 dB(A)
Sound power LWA, guaranteed	101.0 dB(A)
Sound power LWA (Standard)	ISO 6395

#### Operating Fluids

Fuel specification	Diesel EN 590
Fuel Tank capacity	35.0 l

#### Chassis

Turning radius	3,980.0 mm
Articulation angle	36.0 °

Traction drive	Swash plate motor
Hydraulik Pump	Gear pump
Operating pressure	450.0 bar
Flow rate	66.0 l/min

Tires	11.5/80-15,3 14PR 126 A8
-------	--------------------------

### ■ Shipping and Storage

Shipping weight	2,142.0 kg
-----------------	------------

## Dimensions

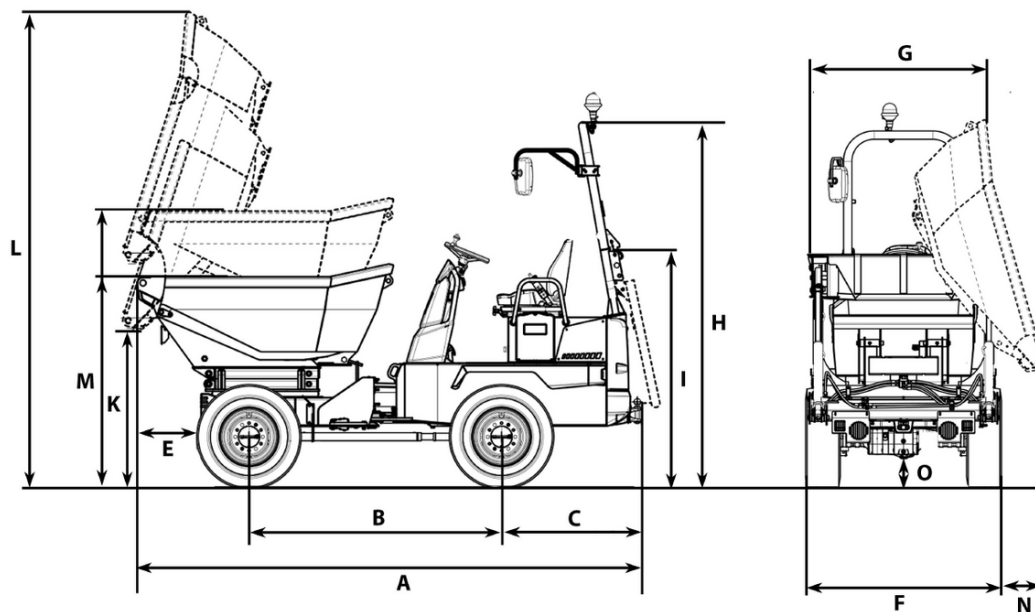

A	Total length	3,904 mm
B	Wheel base	1,945 mm
C	Rear overhang	1,039 mm
E	Dumping width	482 mm
F	Width of vehicle	1,730 mm
G	Width of skip	1,730 mm
H	Height ROPS	2,778 mm
I	Height of ROPS tilted	1,913 mm
J	Height with cab	2,669 mm
K	Dumping height max.	994 mm
L	Skip height tilted	3,082 mm
M	Skip height	1,475 mm